

DRIVEWAY PERMIT FEE \$50.00

<i>Office Use Only</i>
Amount Paid: _____
Date: _____
Recipient Initials: _____

TOWN OF CAMPTON
 12 GEARTY WAY CAMPTON, NH 03223
 603-726-3223 (Town Office Phone)
 603-254-5908 (Road Agent Cell Phone)

APPLICANT'S NAME: _____
 APPLICANT'S MAILING ADDRESS: _____
 APPLICANT'S PHONE NUMBER: _____
 PROPERTY LOCATION: _____
 MAP & LOT NUMBER: _____ DATE: _____

Permission to construct a driveway, entrance, exit, or approach adjoining _____
 _____ Road pursuant to the location and specifications as described below, is hereby granted.

Failure to adhere to the standards and engineering drawing previously submitted, and failure to complete construction of said facility within one calendar year or the date of this permit shall render this instrument null and void. **It is the responsibility of the owner/agent to contact the Road Agent during and after the construction process so that proper construction can be discussed and final approval can be given.** If facilities are constructed in violation of the following conditions, they shall be corrected immediately upon notification by a town representative or the cost of removing said facility shall be fully borne by the owner;

Code Enforcement Officer Use Only

1. This permit requires that the area adjacent to the highway be graded such that surface will slope from the edge of the pavement to a line _____ feet distance from and parallel to the pavement and _____ inches below the edge of the pavement (for the entire frontage of the property) which line will serve as a drainage gutter.
2. _____ driveway entrance (s) is (are) permissible, each not to exceed _____ feet in width. The driveway entrance(s) may be flared as they approach the pavement.
3. Minimum of 12-inch HDPE plastic culvert under drive or other size indicated below.
4. 12" Culvert (minimum) _____ No Culvert Needed _____ Other _____ (check one)
5. No part of the right-of-way may be used for any purpose other than travel.
6. No structures, including building, permanent or portable signs, lights, displays, fences, walls, etc. shall be permitted on, over or under the road(s) right-of-way.
7. The town road right-of-way line is located _____ feet from and parallel to the centerline of the road pavement.
8. No parking, catering or servicing shall be conducted within the Town road right-of-way.
9. Applicant shall comply with all Zoning Ordinances and Regulations specified by the Town of Campton.

Construction Approval Date: _____

Code Enforcement Officer _____

Final Approval Date: _____

 Road Agent

 Board of Selectmen

15" INCH CULVERTS

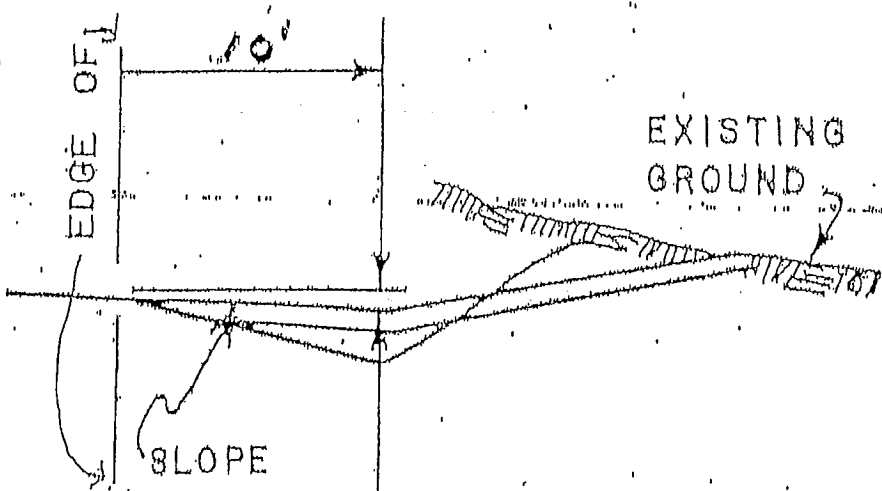
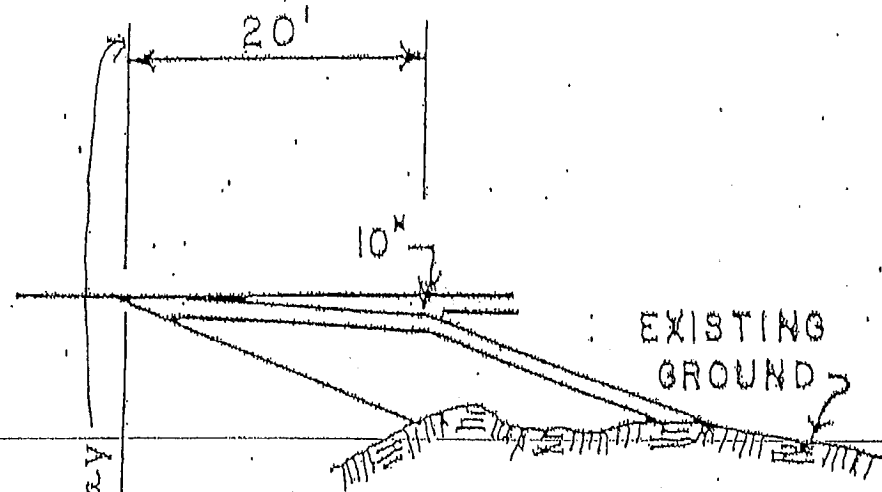

1/2" PER FT. FOR ALL DRIVEWAYS.

DRIVEWAY PROFILE - RURAL